

24 VAC automatic burner control with integrated ignition for atmospheric gas burners DGAI. 70N

DUNGS®

1.30



Technology

DGAI. 70N is an automatic gas burner controller conforming to EN 298 with the following features:

- Supply voltage 24 VAC
- Flame monitoring by ionisation
- Program flow control by electronic timers
- Integrated cyclic spark ignition
- 24 VDC pilot gas valve
- 24 VDC main gas valve, 1st stage
- 24 VDC main gas valve, 2nd stage
- Ignition and flame monitoring with common electrode or with separate ignition and ionisation electrodes
- Recycling
- Visual fault indication by LED
- Volatile lockout

Application

Automatic gas burner controller DGAI. 70N is suitable for igniting and monitoring atmospheric burners designed for intermittent operation. It complies with EN 298.

DGAI. 70N Mod. ... TLL is suitable for decorative fuel effect gas appliances, as it has a start inhibiting function (EN509) which becomes active in the event of a power failure.

Type approval

EC type test approval as per EC Gas Appliance Directive:

DGAI. 70N CE-0085 AS 0328

EC type test approval as per EC Pressure Equipment Directive:

DGAI. 70N CE0036

Automatic gas burner controller DGAI. 70N

DGAI. 70N is installed in a plastic housing with an RAST5 termination system. Assembled on a single pcb, the automatic gas burner controller uses electronic timers. Exact operating times are thereby assured, even in the case of voltage and temperature fluctuation or very short operating cycles.

DGAI. 70N is comprised of:

- the program flow control module,
- the flame monitor which operates according to the ionisation principle,
- the ignition electronics and the integrated ignition coil.

When the controller signals that heat is required, the ignition is activated after a waiting time of 3 seconds at

start-up, and the pilot gas valve is opened. The fault LED blinks briefly to indicate that start-up is in progress. The ignition is switched off when the pilot flame signal is detected. At the end of the safety time (SZA), the main gas valve is opened if the flame is lit. The Mod. 90.3 TLL opens the main valve with a delay of 2 s after the pilot flame signal is detected.

If no flame is formed within the safety time, the ignition is switched off and the control locks in fault mode. If a loss of flame occurs during operation, all gas valves are switched off during the extinction safety time (SZB). The ignition is then disabled in the fault mode, or an attempt to restart the burner is made.

In the case of a normal shut-down, the gas solenoid valves are closed. If a

flame signal is detected before fuel release, start-up is disabled as long as the flame signal is applied.

DGAI. 70N Mod. ... TLL

DGAI. 70N Mod. 10.3 TLL additionally contains an electronic interlocking circuit (EN509) which prevents automatic restarting on restoration of the supply after a power failure. In this case, DGAI. 70N can be started up by switching the request switch R1 off and on again when mains voltage is present.

Fault release

After a fault has been cleared, DGAI. 70N can be released by switching R1 off and on again.

Program flow

- AWZ Waiting time
- FI Flame
- R1 ON/OFF and release
- R2 2nd stage
- ST Fault indication
- SZA Safety time
- SZB Extinction safety
- Y1 Pilot gas valve
- Y2 Main gas valve, 1st stage
- Y3 Main gas valve, 2nd stage
- Z Ignition



Function /circuit diagram

- F1 Back-up fuse, 6.3 A, slow-acting
- FLV Flame monitor
- FW Flame detector relay
- HR Main relay
- IE Ionisation electrode
- IZE Ionisation and ignition electrode
- MB Wire jumper (cuttable)
- R1 ON/OFF and release
- R2 2nd stage
- SAB Start-up disabling circuit
- ST1 Internal fault indication
- ST2 External fault indication
- X1-X7 Terminal designation
- Y1 Pilot gas valve
- Y2 Main gas valve, 1st stage
- Y3 Main gas valve, 2nd stage
- ZE Ignition electrode
- ZKS Time loop circuit
- ZR Timer relay
- ZUB Ignition burner
- ZUS Ignition circuit

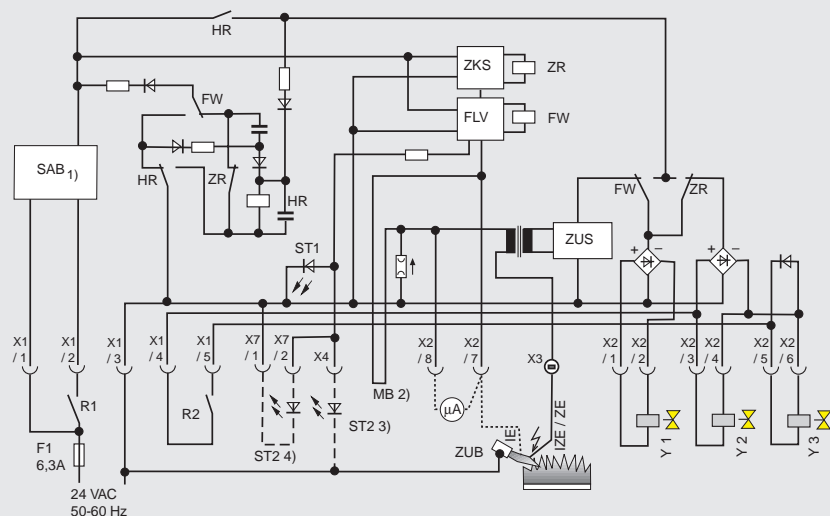

- 1) Mod. 10.3 TLL only
- 2) Cut open jumper for ionisation current measurement or dual probe
- 3) Mod. 10.3 TLL S02 only
- 4) Mod. ... S03 only

Ionisation flame monitoring

An ionisation electrode acts as a flame probe in the flame, and the burner usually serves as the ground. Make sure that proper flame adhesion is ensured on the burner. The burner must be securely connected to terminal X1/3 for feeding back the ionisation current. The insulation resistance of the ionisation electrode should exceed 50 MΩ.

If a separate ionisation electrode is used (dual probe), jumper MB (on the right-hand side of the terminal) must be cut open.

Measuring the ionisation current

The intensity of the ionisation current can be measured with a DC current microammeter. The current intensity should not be less than 3 μA in operation. If the ionisation current drops below 1 μA, the device locks in fault mode.

To measure the ionisation current, connect the microammeter between the ionisation electrode and the connector. If a common ignition and ionisation electrode (single probe) is used, jumper MB must be cut open so that the ionisation current can be measured. Upon completion of the measurement, terminals X2/7 and X2/8 must be bridged in place of jumper MB.

Measuring instrument connection (single probe)

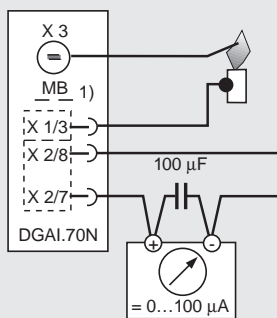

1) cf. Measuring the ionisation current

Measuring instrument connection (dual probe)

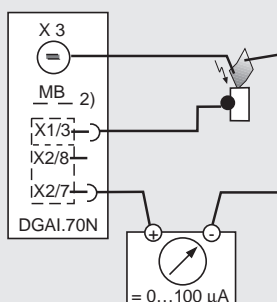

2) cf. Ionisation flame monitoring

Installation

The automatic gas burner controller can be installed in any position.

Electrical connection

The controller is connected by means of RAST5 connectors (cf. Technical specifications). The wiring must be configured in accordance with the applicable local regulations and as shown in the wiring diagram.

⚠ Ignoring the installation and operating instructions may result in injury to persons or damage to property. Compliance with the applicable instructions is therefore imperative. Unauthorised tampering with the electronics will render the warranty on this equipment null and void.

⚠ For dual probe, jumper MB must be cut, otherwise the flame signal will also be detected via the ignition electrode.

Starting up

Before starting up the DGAI. 70N, all connections must be checked for correctness. When the DGAI. 70N is placed in service, the following safety functions are to be checked:

- Switch-off of controllers, monitoring devices and limiters (if installed)
- Switching points of the gas pressure switch (if installed)
- Flame monitor (cut ionisation line, or short the electrode to ground).

Fuses

The automatic burner control is to be protected externally using a 6.3A slow-acting back-up fuse or a 10A fast-acting fuse. Pay attention to the permissible switching capacities.

⚠ If a fuse is faulty, the safety of the automatic burner control must be checked, as there is a risk of contact welding due to a short circuit.

Wiring diagram (single probe)

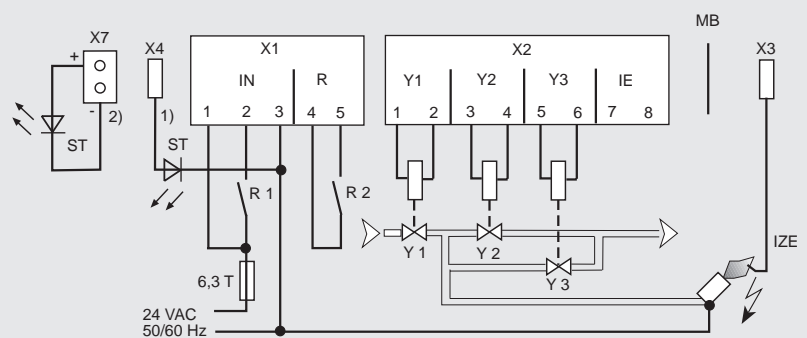

Wiring diagram (dual probe)

1) only DGAI. 70N Mod. 10.3 TLL S02 (LED 10 mA)

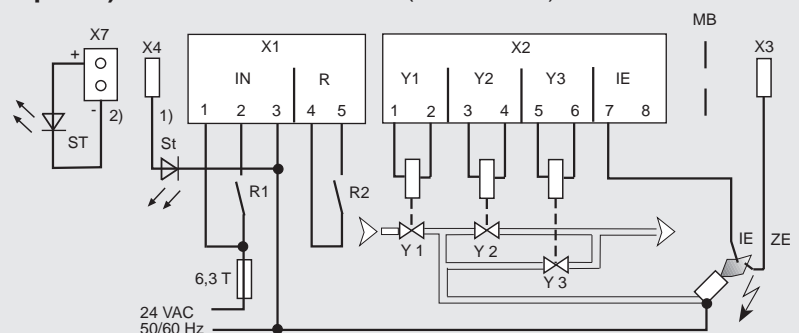

IE Ionisation electrode
IZE Ionisation and ignition electrode
MB Wire jumper
R1 ON/OFF and release
R2 2nd stage
ST External fault indication

X1-X7 Terminal designation
Y1 Pilot gas valve
Y2 Main gas valve, 1st stage
Y3 Main gas valve, 2nd stage
ZE Ignition electrode

**24 VAC automatic burner control
with integrated ignition for atmos-
pheric gas burners**

DGAI. 70N

DUNGS®

Dimensions

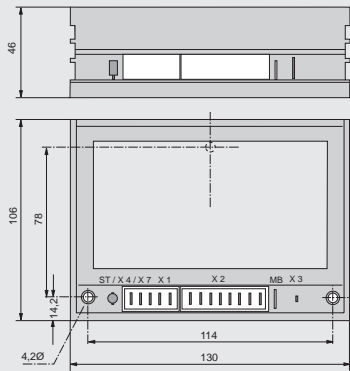

Technical specifications

Nominal voltage	24 VAC, ±15%
Frequency	50 Hz
Power consumption	approx. 5 VA
Internal fuse	non-interchangeable
Back-up fuse	max. 6.3A, slow-acting,
10A fast-acting	
Switching capacities:	
Pilot valve	24V DC/1A
Main valve, 1 st stage	24V DC/1A
Main valve, 2nd stage	24V DC/1A
Overall switching capacity	max. 2A
Important: only use DC valves	
Flame detector	Ionisation
Ionisation current/duty	> 3 µA
Cut-off sensitivity	< 1 µA (>0.5 µA)
Short-circuit current limitation	approx. 100 µA
Ignition	integrated spark ignition
Open circuit voltage	> 15 kV
Spark frequency	< 4 Hz
Spark gap	3-4 mm
Ignition lead length	< 1 m
Fault release	Remote release via R1
Degree of protection	IP 20 - IP 40 must be provided by installation
Ambient temperature	0-60 °C
Termination system	RAST5, coded
PE connection	separate
Weight	0.35 kg

DGAI. 70N Table of connectors

Funktion	Slot . No.	Number of poles	Code Con- nector -No.
Ionisation measuring	IE	02	... ¹⁾ 02 K60
Supply voltage	IN	03	... ¹⁾ 03 K06
Switch, 2nd stage	R	02	... ¹⁾ 02 K01
High-voltage connection	X3	01	FAST-ON 2.8 x 0.8 mm
External fault indication	X4	01	FAST-ON 2.8 x 0.8 mm
	X7	02	¹⁾ Stocko...
Pilot valve	Y1	02	... ¹⁾ 02 K04
Main valve, 1st stage	Y2	02	... ¹⁾ 02 K16
Main valve, 2nd stage	Y3	02	... ¹⁾ 02 K05

¹⁾ Lumberg: insulation piercing connecting device 3623.../
Screw terminal 3611...

²⁾ Stocko MKH 19002-6-200

Ordering data Type	Order No.	Classification to EN 298	Safety time	Flame response time	Recy- cling	Fault indica- tion internal	Fault indication ex- ternal
DGAI. 70N Mod. 10.3 TLL	226 132	ATVWXN	10 s	3 s	○	●	○
DGAI. 70N Mod. 10.3 TLL S02	226 244	ATVWXN	10 s	3 s	○	○	●
DGAI. 70N Mod. 10.3 TLL S03	242 018	ATVWXN	10 s	3 s	○	○	●
DGAI. 70N Mod. 90.3 TLL	232 217	ATVWXN	90 s	3 s	○	○	●
DGAI. 70N Mod. 90.3 TLL S03	242 019	ATVWXN	90 s	3 s	○	○	●
DGAI. 70N Mod. 5.1 TCV	226 134	ATCVXN	5 s	1 s	●	●	○
DGAI. 70N Mod. 10.3 TCV	226 133	ATCVXN	10 s	3 s	●	●	○
DGAI. 70N Mod. 5.1 TVV	226 135	ATVWXN	5 s	1 s	○	●	○
Terminal-Set DGAI. 70N	227 371	(Screw terminal)					
External fault indication	243 849	for Mod. ... S03, LED with cable and plug					

We reserve the right to make any changes in the interest of technical progress.

Head Offices and Factory
Karl Dungs GmbH & Co. KG
Siemensstraße 6-10
D-73660 Urbach, Germany
Telephone +49 (0)7181-804-0
Fax +49 (0)7181-804-166

Postal address
Karl Dungs GmbH & Co. KG
Postfach 12 29
D-73602 Schorndorf, Germany
e-mail info@dungs.com
Internet www.dungs.com